



# Power Supply/Battery Chargers

## Installation Instructions

ALARM SAF

### I. Model Numbers

Item Number	Model Number	System Voltage	System Current	Maximum Battery Capacity	Maximum AC Input Current	XFMR Voltage	Battery Storage in Cabinet
008-09	PS3-BFS-12	12VDC	3.0A	34Ah	1.25A	17.5VAC	20Ah Max
008-10	PS3-BFS-24	24VDC	3.0A	34Ah	2.50A	28.2VAC	8Ah Max
008-25	PS3-BFS-12-CAN	12VDC	3.0A	34Ah	1.25A	17.5VAC	20Ah Max
008-26	PS3-BFS-24-CAN	24VDC	3.0A	34Ah	2.50A	28.2VAC	8Ah Max
008-11	PS5-BFS-12	12VDC	4.0A	50Ah	1.25A	17.5VAC	20Ah Max
008-12	PS5-BFS-24	24VDC	4.0A	50Ah	2.50A	28.2VAC	8Ah Max
008-27	PS5-BFS-12-CAN	12VDC	4.0A	50Ah	1.25A	17.5VAC	20Ah Max
008-28	PS5-BFS-24-CAN	24VDC	4.0A	50Ah	2.50A	28.2VAC	8Ah Max

### II. Installation Instructions

- Mount cabinet per mechanical dimensions and knockout locations given in Section IV.
- Connect 120VAC, 60Hz., single phase to the black and white leads of the transformer in accordance with Article 725 of the National Electrical Code, Article 16 of the Canadian Electrical Code, or other applicable codes. -EUR (European) versions connect 240VAC, single phase.
- Low Volt AC Input - Connect to secondary winding of the transformer.  
Fused at 10 Amps (Fuse Type AGC-10)
- Verify output voltage at "DC Output" and "Battery" terminals.  
12V system measures approximately 13.8VDC.  
24V system measures approximately 27.6VDC.
- Connect battery set to "Battery" terminals.  
CAUTION: Observe polarity; incorrect polarity will destroy battery fuse.  
Fused at 10 Amps (Fuse Type AGC-10).  
Recommended battery type - PowerSonic (PS-Series) or YUASA (NP-Series) sealed lead acid/gel cell.
- Connect "DC Output" to input of user system.  
CAUTION: Observe polarity; incorrect polarity may damage user system.  
Refer to Section I for Maximum Allowable System Current.
- Visual Indicators:  
AC Presence LED1: Green LED  
Fault Condition LED3: Yellow LED  
LED2 (Red LED) serves no user function.
- Connect "Fault Output" to system fault annunciation; Voltage output, current limited by 470 ohm resistor.  
12V system short circuit fault current is approximately 25mA.  
24V system short circuit fault current is approximately 50mA.  
CAUTION: Observe polarity.  
For relay output: Use Relay Module AS/RBKS-124P or AS/RBKS-124N: See Section III.
- Fault Conditions: Low AC / No AC / Blown AC Fuse / Low Battery / Blown Battery Fuse  
CAUTION: Fault condition reporting may be delayed dependent on power supply loading.  
The battery set is NOT supervised for presence.
- Battery Standby Information:
  - For 60 hr. standby with 34Ah battery set - Max standby draw: 0.5A, Max 5 minute alarm current: 2A.
  - For 24 hr. standby with 34Ah battery set - Max standby draw: 1A, Max 5 minute alarm current: 2A.
  - For 4 hr. standby with 20Ah battery set - Max standby draw: 3A, Max 5 minute alarm current: 4A.
- Power Supply System Draw (No AC, No load) is 25mA.

### III. Typical Hook-up Diagrams

{ To Convert the Voltage Fault Output to a Form C relay contact output  
The relay will activate on a fault condition.

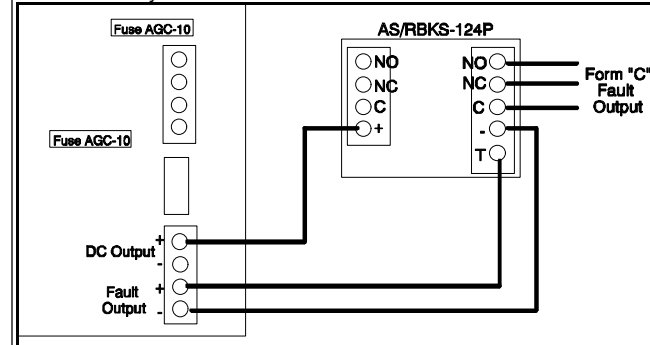

{ To Convert the Voltage Fault Output to a Form C relay contact output  
The relay will activate on a fault condition.

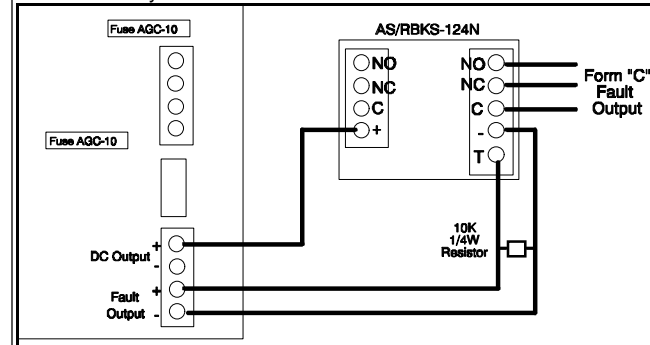

{ Switch Settings

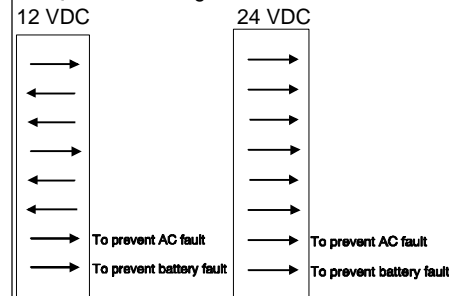

{ Terminal Layout

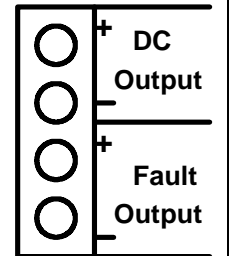
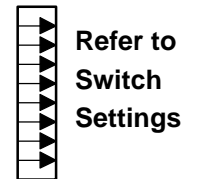
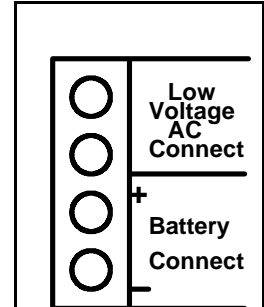

# Power Supply/Battery Chargers

## Installation Instructions

### IV. Mechanical Drawing

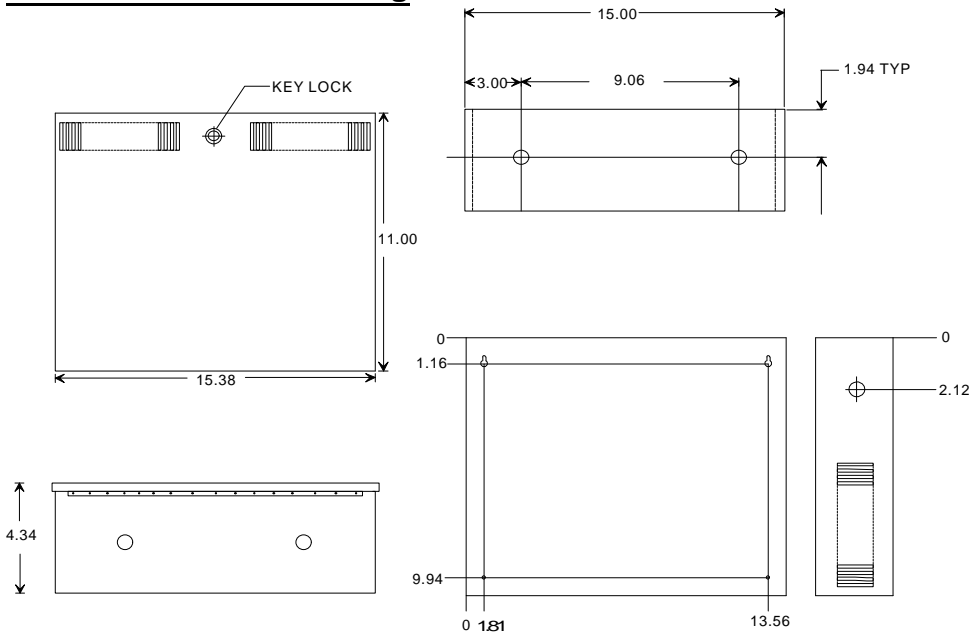

### V. Hook-Up Diagram

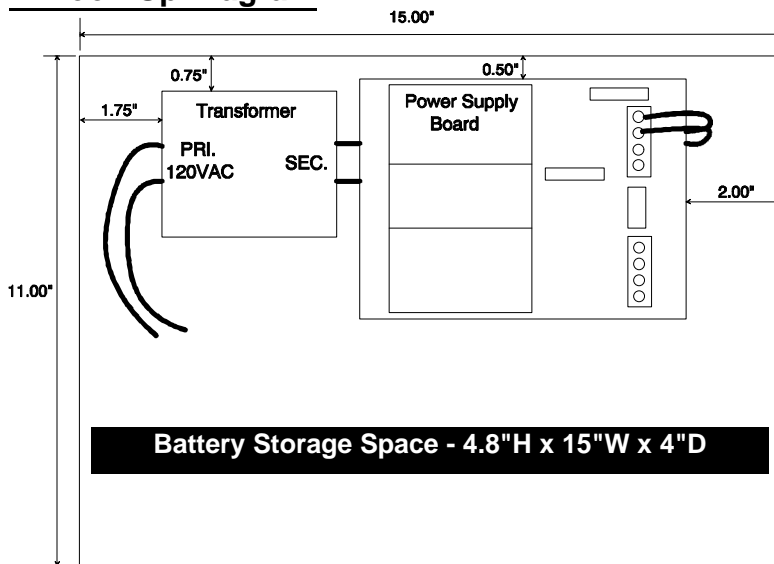

### VI. Troubleshooting Guide

#### Fault Output

- v Voltage output, current limited by 470 ohm resistor.
  - { 12V system short circuit fault current is approximately 25mA.
  - { 24V system short circuit fault current is approximately 50mA.
- v CAUTION: Observe polarity
- v AS/RBKS-124N required to detect AC fault when no batteries are connected.

#### Visual Indicators

1. AC Presence LED1: Green LED
2. Fault Condition LED3: Yellow LED
3. LED2 (Red LED) serves no user function.
4. **Fault Conditions**
  - Flashing Yellow LED on:
    - Low AC / No AC / Blown AC Fuse
    - Low Battery
    - Blown Battery Fuse

### VII. Troubleshooting Chart

Symptoms	Possible Cause	Correction Procedure
1) Yellow "Fault" LED is blinking. DC voltage at "Fault Output"	Low AC / No AC / Blown AC fuse.	See Symptom 2.
	Low battery.	See Symptom 3.
	Blown battery fuse.	See Symptom 4.
2) Green "AC" LED is not illuminated.	Loss of AC power.	Check AC primary supply.
	Blown AC fuse.	Remove primary power and batteries, then replace fuse. CAUTION.
	Loss of transformer (xfmr) power.	Check xfmr secondary voltage at PC board "Low Voltage AC Connection". If voltage is not present, replace xfmr.
3) Incorrect output voltage	Defective battery.	Check battery condition and replace if needed.
	The system load is greater than the supply capability.	Remove system load and batteries; check system output voltage. If OK recheck system requirements, and/or measure output current draw with an ammeter.
	Incorrect battery hook-up.	Rewire battery set.
	Incorrect or defective xfmr.	Measure xfmr secondary voltage. If not within proper range, replace transformer.
	Incorrect switch setting.	Verify switch settings in Section III.
4) No battery back-up	Blown battery fuse.	Remove primary power and batteries, then replace fuse. CAUTION.
	Incorrect battery hook-up.	Rewire battery set.