



12 VDC @ to 1 Amp

The FMC Power Supply / Charger provides 12 VDC at to 1 amperes •for use in powering access control, burglar, and auxiliary control systems. The units are available in several UL versions with a class 2 transformer and painted steel , locking enclosure for a secure installation. The self contained battery •capacity ranges from 4 to 14 amphours.

DIMENSIONS

Cabinet Size

- FMC-12/10-BFS-UL
 - 8"H x 7"W x 3.5"D
 - 20.3cm x 17.8cm x 8.9cm
- FMC-12/15-BFS-UL
 - 12"H x 12"W x 4"D
 - 30.5cm x 30.5cm x 10.16cm

Cabinet Weight

- FMC-12/10-BFS-UL
 - 5 lbs. 1 oz., 2.34 kg Less Batteries
- FMC-12/15-BFS-UL
 - 8 lbs. 5 oz., 3.77 kg Less batteries

Battery Space

- FMC-12/10-BFS-UL
 - 4 "H x 7"W x 3.5"D
 - 10.8cm x 17.8cm x 8.9cm
- FMC-12/15-BFS-UL
 - 4 "H x 12"W x 4"D
 - 10.8cm x 30.5cm x 10.16cm

SPECIFICATIONS

Input Characteristics

- FMC-12/10-BFS/UL
 - 16.5VAC, +/- 10%, 1 Phase, 2 Amp max., 40 VA
- FMC-12/15-BFS/UL
 - 16.5VAC, +/- 10%, 1 Phase, 3 Amp max., 50 VA

Output Characteristics

- FMC-12/10-BFS/UL
 - Power Limited
 - Voltage: 12VDC Nominal, Set @ 13.2VDC
 - Current: ADC
 - Ripple:005VAC_{RMS} @ ADC
 - Battery Capacity: ... 4 Ah
- FMC-12/15-BFS/UL
 - Power Limited
 - Voltage: 12VDC Nominal, Set @ 13.2VDC
 - Current: 1 ADC
 - Ripple:005VAC_{RMS} @ ADC
 - Battery Capacity: ... 14 Ah

Overcurrent Protection

- Electronically Limited
- Battery Reverse Polarity Protection: PTC*
- Electronically Limited Regulators
- Thermal Protection: Electronically Limited
- Battery Chemistry: Lead Acid

Fault Detection Conditions Reported

- High Battery
- Low Battery
- AC Fuse/AC Presence
- Battery Fuse

Visual Indicators

- AC Presence: Green LED
- Faults: Yellow LED

Temperature Range

- 32°F to 120°F
- 0°C to 50°C

Humidity

- 85% @ 85°F (29.4°C)

* Polswitch Circuit Protector

LISTINGS

UL

- UL 294: Access Control System Units

TYPICAL USES

- Auxiliary Power for access control
- System Power for access control
- Proximity Reader Power
- Card Reader Power
- DC CCTV Camera Power
- Auxiliary Battery Charger
- Door Strike Power
- Maglock Power

ORDER INFORMATION

Order Information		Output		Physical Information				Application	
Order#	Model Number	Voltage	Current	Charge Capacity	Cabinet Space	Supplied Batteries	Cabinet	Power Limited	Access
01401	FMC-12/10-BFS/UL	12 VDC	A	4 Ah	4 Ah		B01	•	•
01402	FMC-12/10-BFS/UL-1B4	12 VDC	A	4 Ah	4 Ah	4 Ah	B01	•	•
01403	FMC-12/15-BFS/UL	12 VDC	1 A	14 Ah	14 Ah		B02	•	•
01404	FMC-12/15-BFS/UL-2B7	12 VDC	1 A	14 Ah	14 Ah	14 Ah	B02	•	•

TYPICAL LAYOUT

B01 Cabinet

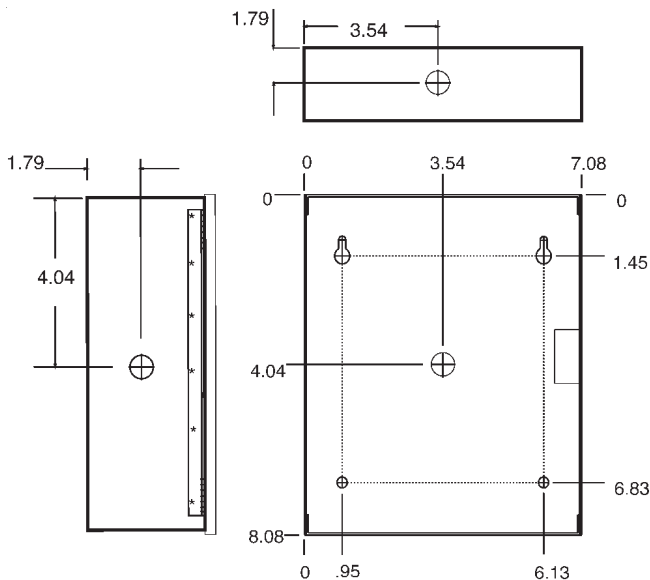

B02 Cabinet

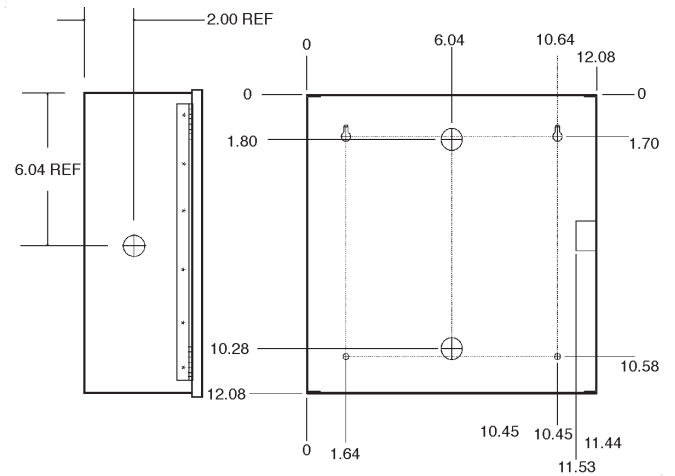

ALARM SAF

65A Industrial Way, Wilmington, MA 01887-3499, USA, Voice:978-658-6717, Fax:978-658-8638, www.alarmsaf.com